

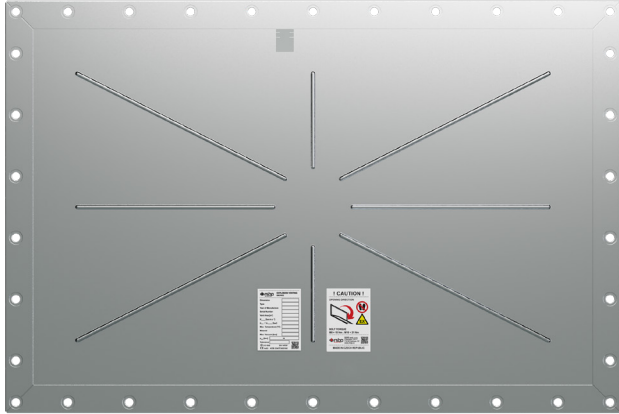

VENT PRO F - EXPLOSION VENTING DEVICE



It is a safety device designed to relieve and release an explosion that might occur inside the protected equipment, where there is an environment with a risk of explosion. Under normal operating conditions, the relief area on the protected equipment is covered by VENT PRO F. If the p_{stat} is exceeded during an explosion inside the equipment, VENT PRO F will open, thus releasing the pressure from the jeopardized area. The equipment will be exposed to a pressure lower than its pressure resistance.

This data sheet describes the technical parameters of VENT PRO F. These VENT PRO have a single-layer construction and are flat. They are manufactured in a rectangular design and they are in accordance with EN 14797 and European Directive 2014/34/EU.

VENT PRO F CLASSIFICATION

Equipment group	II
Explosive atmosphere	D
Equipment category, indoor/outdoor	1/2G, 1/2D
Operating temperature	-40 °C to 100 °C
Storage temperature	-10 °C to 40 °C
Standard static opening pressure*	10 kPa ± 15 %

* Can also be supplied with a different static opening pressure

MATERIAL DESIGN

VENT PRO F	stainless steel
Sealing	EPDM (alt. exp. silicone)

OPTIONAL ACCESSORIES

Opening indicator	cable (G1), magnetic (G2), additional (G3) or induction (G4)
Intrinsically safe relay	it is used to create the interface between the safe and dangerous zone
Thermal insulation	synthetic rubber-based foam
Fasteners	screws - (strength 8.8 or A2-70), nuts ISO 4032, washers ISO 7089 (all in galvanized finish or stainless-steel design)

DIMENSIONAL DIAGRAM

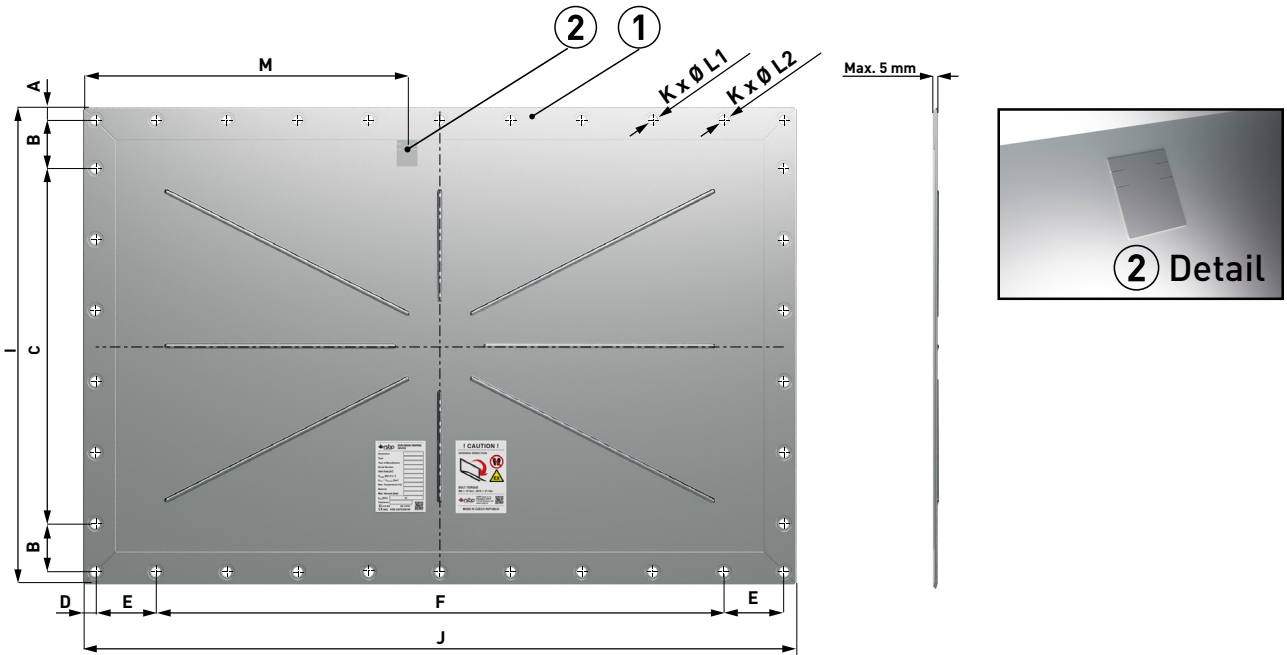

INSTALLATION VARIANTS

Installing with bolts

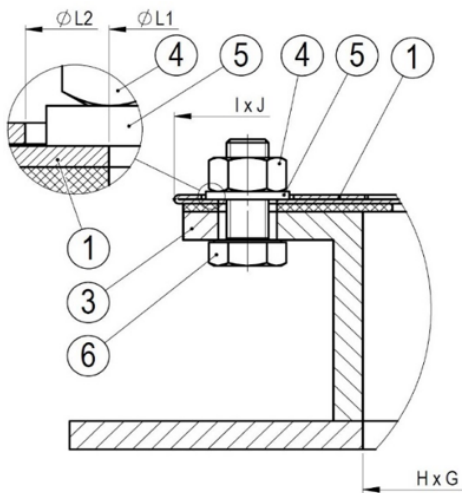

Installing with welded screws

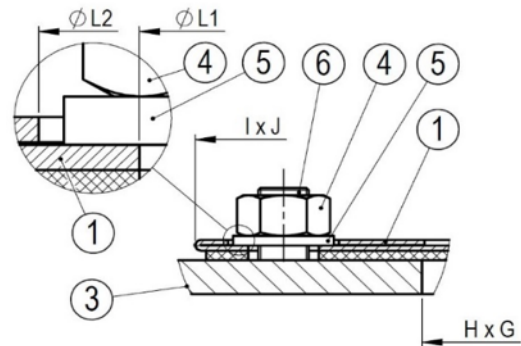

Position	Components	Quantity
①	VENT PRO F	1
②	opening indicator plate VENT PRO	1
③	protected equipment ¹⁾	1
④	nut ²⁾	see ³⁾
⑤	washer ²⁾	see ³⁾
⑥	screw ²⁾	see ³⁾

¹⁾ For the installation of VENT PRO F, the flange of the protected equipment must meet the requirements of standard EN ISO 13920-BE and must be sufficiently rigid. In case of mounting on insufficiently rigid equipment, it is necessary to provide the flange with additional reinforcement.

The diameters of the holes in the flange of the protected device for M10 screws are $\phi 12$ mm, for M8 screws are $\phi 10$ mm (EN 20273).

²⁾ Material - galvanized steel or stainless steel (screws strength 8.8 or A2-70).

³⁾ Number according to technical parameters table.

TECHNICAL PARAMETERS

Dimensions	Vent area [m ²]	Hole dimension in protected equipment H x G [mm]	Outer diameter I x J [mm]	A [mm]	B [mm]	C [mm]		D [mm]	E [mm]	F [mm]		Screws / Holes in the VENT PRO			M [mm]	Max. vacuum [bar]	
						Number of holes	Spacing			Number of holes	Spacing	K	Screw size	ØL1 [mm]			ØL2 [mm]
170x470	0.08	170x470	250x550	15.0	70.0	2	80.0	15.0	110.0	4	100.0	M10	16	12	22	275.0	
220x540	0.12	220x540	308x628	20.0	90.0	2	88.0	20.0	98.0	5	98.0	M10	18	14	22	265.0	
229x229	0.05	219x219	309x309	14.5	93.0	2	94.0	14.5	93.0	2	94.0	M10	12	12	21	154.5	
229x305	0.06	219x295	309x385	14.5	93.0	2	94.0	14.5	76.0	3	102.0	M8	14	9	18	243.5	
241x762	0.18	241x762	331x852	20.0	90.0	2	111.0	20.0	116.0	6	116.0	M10	20	14	22	310.0	
247x610	0.15	247x610	327x690	15.0	98.5	2	100.0	15.0	80.0	6	100.0	M10	20	13	21	445.0	
260x260	0.07	260x260	337x337	14.5	103.0	2	102.0	14.5	103.0	2	102.0	M10	12	12	21	168.5	
270x458	0.12	270x458	350x538	20.0	100.0	2	110.0	20.0	99.0	4	100.0	M10	16	13	22	169.0	
300x500	0.15	300x500	382x589	16.1	75.0	3	100.0	19.4	75.0	5	100.0	M10	20	14	22	344.4	
305x457	0.14	300x451	390x541	17.0	76.0	3	102.0	17.0	102.0	4	101.0	M10	18	14	22	270.5	
350x650	0.23	350x650	430x730	15.0	100.0	3	100.0	15.0	100.0	6	100.0	M10	22	12	21	365.0	
375x655	0.25	375x655	460x740	15.0	140.0	2	150.0	15.0	130.0	4	150.0	M10	16	12	21	520.0	
410x410	0.17	410x410	490x490	20.0	150.0	2	150.0	20.0	150.0	2	150.0	M8	12	9	18	245.0	
450x800	0.37	450x800	550x900	25.0	125.0	3	125.0	25.0	110.0	6	126.0	M10	22	14	30	450.0	
457x890	0.39	447x880	537x970	15.0	102.0	4	101.0	15.0	114.0	8	"	M10	28	14	22	485.0	
490x590	0.28	485x585	573x673	21.5	90.0	5	"	21.5	90.0	6	90.0	M10	26	14	30	336.5	
500x750	0.38	500x750	580x830	17.0	73.0	5	100.0	17.0	98.0	7	100.0	M10	28	14	22	465.0	
520x720	0.37	520x720	600x800	15.0	85.0	5	100.0	15.0	85.0	7	100.0	M10	28	14	22	450.0	
578x851 US	0.47	559x845	644x930	15.9	96.7	4	139.7	15.9	128.3	6	128.3	M8	24	9	18	465.0	
578x851	0.49	578x851	658x931	22.7	102.3	5	102.0	16.1	99.4	8	100.0	M10	30	14	22	465.5	
580x410	0.24	410x580	500x670	20.0	92.0	4	92.0	20.0	105.0	5	105.0	M10	22	14	22	282.5	
586x920	0.53	581x915	671x1005	17.0	68.0	6	100.0	17.0	85.0	9	100.0	M10	34	14	22	452.5	
588x908	0.53	588x908	680x1000	17.0	161.5	3	161.5	17.0	138.0	6	138.0	M10	22	14	22	500.0	
600x600	0.35	590x590	656x656	58.0	180.0	2	180.0	58.0	180.0	2	180.0	M8	16	9	18	328.0	
610x470	0.29	470x610	550x690	15.0	105.0	4	"	15.0	80.0	6	100.0	M10	24	12	21	445.0	
610x610	0.37	610x610	690x690	15.0	110.0	5	110.0	15.0	110.0	5	110.0	M8	24	9	18	400.0	
630x310	0.19	305x625	385x705	16.0	118.0	2	117.0	16.5	112.0	5	112.0	M10	18	14	22	408.5	
685x1100	0.76	685x1100	765x1178	15.0	105.0	6	105.0	15.0	114.0	9	115.0	M10	34	14	21	646.5	
720x1020	0.73	720x1020	800x1100	15.0	85.0	7	100.0	15.0	85.0	10	100.0	M10	38	13	21	550.0	
782x882	0.69	782x882	890x990	19.0	76.0	8	100.0	19.0	76.0	9	100.0	M10	38	14	22	545.5	
800x800	0.62	790x790	853x853	56.5	185.0	3	185.0	56.5	185.0	3	185.0	M8	20	9	18	519.5	
870x910	0.79	870x910	960x1000	18.0	77.0	8	110.0	18.0	97.0	8	110.0	M10	36	14	22	500.0	
915x1118	1.02	915x1118	1000x1203	17.5	82.5	9	100.0	17.5	111.5	10	105.0	M10	42	14	22	601.5	
920x920	0.83	915x915	1005x1005	17.5	85.0	9	100.0	17.5	85.0	9	100.0	M10	40	14	22	452.5	
920x1380	1.27	920x1380	1000x1460	15.0	85.0	9	100.0	15.0	115.0	13	100.0	M10	48	14	21	780.0	
940x1440	1.33	930x1430	1002x1502	51.0	150.0	5	150.0	51.0	100.0	9	150.0	M10	36	12	22	826.0	
980x980	0.96	980x980	1120x1120	25.0	160.0	6	150.0	25.0	160.0	6	150.0	M10	28	14	22	560.0	
1000x1000	0.99	996x996	1064x1064	17.5	147.0	6	147.0	17.5	147.0	6	147.0	M10	28	12	21	532.0	
1000x2000	2.00	1000x2000	1090x2090	18.0	87.0	9	110.0	18.0	92.0	18	110.0	M10	58	14	22	1155.0	
1110x1460	1.62	1110x1460	1192x1542	16.0	80.0	11	100.0	16.0	105.0	14	100.0	M10	54	13	22	771.0	
1118x1118	1.25	1118x1118	1202x1202	16.8	76.2	11	101.6	16.8	76.2	11	101.6	M10	48	14	22	651.8	
1020x1020	1.03	1015x1015	1106x1106	18.0	107.0	9	107.0	18.0	107.0	9	107.0	M10	40	14	22	606.5	
1130x1130	1.28	1130x1130	1220x1220	20.0	90.0	11	100.0	20.0	90.0	11	100.0	M10	48	14	22	660.0	

-0.05

¹¹ Contact the manufacturer for more information and another dimensions.
 Use screws (ISO 4017), flat washers (ISO 7089) and nuts (ISO 4032) to secure the VENT PRO F.
 Comply with a bolt torque of 15 Nm (M8) and of 21 Nm (M10).
 The diameters of the holes in the flange of the protected device for M10 screws are Ø12 mm, for M8 screws are Ø10 mm (EN 20273).
 The values of maximum vacuum are for VENT PRO F with a static opening pressure of 10 kPa.