



VENT PRO T - RECTANGULAR EXPLOSION VENTING DEVICE



It is a safety device designed to relieve and release an explosion that might occur inside the protected equipment, where there is an environment with a risk of explosion. Under normal operating conditions, the relief area on the protected equipment is covered by VENT PRO T. If the p_{stat} is exceeded during an explosion inside the equipment, VENT PRO T will open, thus releasing the pressure from the jeopardized area. The equipment will be exposed to a pressure lower than its pressure resistance.

This data sheet describes the technical parameters of VENT PRO T. These VENT PRO T have a convex three-layer construction and high vacuum resistance. They are manufactured in a circular and rectangular design and they are in accordance with EN 14797 and European Directive 2014/34/EU.

VENT PRO T CLASSIFICATION

| | |
|------------------------------------|------------------|
| Equipment group | II |
| Explosive atmosphere | G, D |
| Equipment category, indoor/outdoor | 1/2G, 1/2D |
| Operating temperature | -40 °C to 240 °C |
| Storage temperature | -10 °C to 40 °C |
| Standard static opening pressure | 10 kPa ±15 % |

* Can also be supplied with a different static opening pressure

MATERIAL DESIGN

| | |
|------------|-----------------|
| VENT PRO T | stainless steel |
| Sealing | PTFE |

OPTIONAL ACCESSORIES

| | |
|--------------------------|--|
| Opening indicator | cable (G1), magnetic (G2), additional (G3) or induction (G4) |
| Intrinsically safe relay | It is used to create the interface between the safe and dangerous zone |
| Flange gasket | EPDM, silicon |
| Thermal insulation | synthetic rubber-based foam |
| Fasteners | screws - (strength 8.8 or A2-70), nuts ISO 4032, washers ISO 7089 (all in galvanized finish or stainless-steel design) |
| Upper frame | made of stainless steel or constructional steel, galvanized |

DIMENSIONAL DIAGRAM

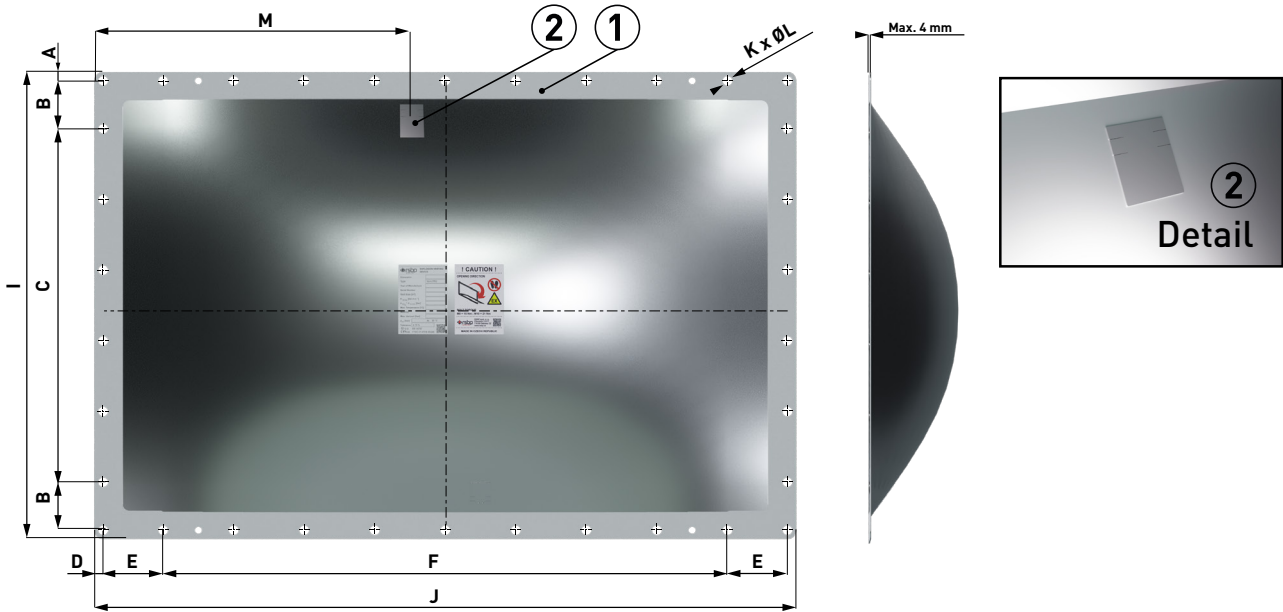

INSTALLATION VARIANTS

Installing with bolts

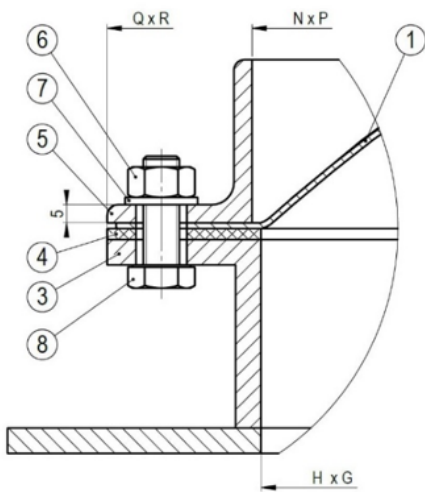

Installing with welded screws

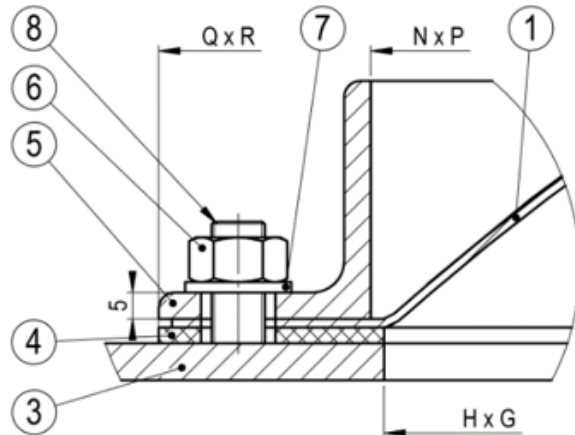

| Position | Components | Quantity |
|----------|-----------------------------------|-------------------|
| ① | VENT PRO T | 1 |
| ② | opening indicator plate VENT PRO | 1 |
| ③ | protected equipment ¹⁾ | 1 |
| ④ | flange gasket ⁵⁾ | 1 |
| ⑤ | upper frame ^{2), 3)} | 1 |
| ⑥ | nut ³⁾ | see ⁴⁾ |
| ⑦ | washer ³⁾ | see ⁴⁾ |
| ⑧ | screw ³⁾ | see ⁴⁾ |

¹⁾ For the installation of VENT PRO T, the flange of the protected equipment must meet the requirements of standard EN ISO 13920-BE and must be sufficiently rigid. In case of mounting on insufficiently rigid equipment, it is necessary to provide the flange with additional reinforcement.

The diameters of the holes in the flange of the protected device for M10 screws are $\varnothing 12$ mm [EN 20273].

²⁾ The frame is made out of 40x40x5 L-shaped steel. In case there is a risk of rainwater remaining in the upper frame, it is necessary to create drainage channels 12 mm wide and 5 mm high in suitable places in it.

³⁾ Material - galvanized steel or stainless steel (screws strength 8.8 or A2-70).

⁴⁾ Number according to technical parameters table.

⁵⁾ A suitable sealant can be used instead of the flange gasket.

TECHNICAL PARAMETERS

| Dimensions | Vent area [m ²] | Hole dimension in protected equipment H x G [mm] | Outer diameter I x J [mm] | A [mm] | B [mm] | C [mm] | | D [mm] | E [mm] | F [mm] | | Screws / Holes in the VENT PRO | | M [mm] | Frame internal dimension N x P [mm] | Frame, seat and flange external dimension Q x R [mm] | Max. vacuum [bar] |
|------------------|-----------------------------|--|---------------------------|--------|--------|-----------------|---------|--------|--------|-----------------|---------|--------------------------------|---------|--------|-------------------------------------|--|-------------------|
| | | | | | | Number of holes | Spacing | | | Number of holes | Spacing | K | ØL [mm] | | | | |
| 220x540 | 0.10 | 220x540 | 300x620 | 16.0 | 90.0 | 2 | 88.0 | 16.0 | 98.0 | 5 | 98.0 | 18 | | 261.0 | 300x620 | -1.00 | |
| 229x229 | 0.04 | 229x229 | 309x309 | 14.5 | 93.0 | 2 | 94.0 | 14.5 | 93.0 | 2 | 94.0 | 12 | 14 | 154.5 | 315x315 | -1.00 | |
| 260x260 | 0.05 | 260x260 | 340x340 | 16.0 | 103.0 | 2 | 102.0 | 16.0 | 103.0 | 2 | 102.0 | 12 | | 170.0 | 345x345 | -1.00 | |
| 305x457 | 0.11 | 300x452 | 375x527 | 9.5 | 76.0 | 3 | 102.0 | 10.0 | 102.0 | 4 | 101.0 | 18 | | 263.5 | 385x537 | -0.90 | |
| 340x440 | 0.13 | 340x440 | 400x500 | 13.0 | 93.5 | 3 | 93.5 | 13.0 | 118.5 | 3 | 118.5 | 16 | 13 | 309.25 | 400x500 | -0.90 | |
| 450x800 | 0.32 | 450x800 | 530x880 | 15.0 | 125.0 | 3 | 125.0 | 15.0 | 110.0 | 6 | 126.0 | 22 | | 440.0 | 535x885 | -0.75 | |
| 457x890 | 0.37 | 457x890 | 537x970 | 15.0 | 102.0 | 4 | 101.0 | 15.0 | 114.0 | 8 | " | 28 | 14 | 485.0 | 537x970 | -0.50 | |
| 490x590 | 0.25 | 485x585 | 565x665 | 17.5 | 90.0 | 5 | " | 17.5 | 90.0 | 6 | 90.0 | 26 | | 332.5 | 570x670 | -0.90 | |
| 586x920 | 0.48 | 581x915 | 661x995 | 12.5 | 68.0 | 6 | 100.0 | 12.5 | 85.0 | 9 | 100.0 | 34 | 16 | 447.5 | 666x1000 | -0.55 | |
| 610x290 | 0.14 | 285x605 | 365x685 | 11.5 | 114.0 | 2 | 114.0 | 12.5 | 110.0 | 5 | 110.0 | 18 | | 397.5 | 370x690 | -0.80 | |
| 2x610x290 | 0.28 | 2x285x605 | 385x1385 | 21.5 | 114.0 | 2 | 114.0 | 21.5 | 122.0 | 10 | 122.0 | 34 | 14 | " | 390x1390 | -0.80 | |
| 630x310 | 0.16 | 305x625 | 385x705 | 16.0 | 118.0 | 2 | 117.0 | 16.5 | 112.0 | 5 | 112.0 | 18 | | 408.5 | 390x710 | -0.80 | |
| 2x630x310 | 0.32 | 2x305x625 | 385x1385 | 16.0 | 118.0 | 2 | 117.0 | 16.0 | 123.0 | 10 | 123.0 | 34 | | " | 410x1410 | -0.80 | |
| 915x1118 | 0.95 | 910x1113 | 990x1193 | 12.5 | 82.5 | 9 | 100.0 | 12.5 | 111.5 | 10 | 105.0 | 42 | | 596.5 | 995x1198 | -0.30 | |
| 920x920 | 0.78 | 915x915 | 995x995 | 12.5 | 85.0 | 9 | 100.0 | 12.5 | 85.0 | 9 | 100.0 | 40 | 16 | 447.5 | 1000x1000 | -0.35 | |
| 1020x1020 | 0.96 | 1015x1015 | 1095x1095 | 12.5 | 107.0 | 9 | 107.0 | 12.5 | 107.0 | 9 | 107.0 | 40 | | 601.0 | 1100x1100 | -0.30 | |

¹⁾Contact the manufacturer for more information and another dimensions.

Use M10 screws, flat washers 10 (ISO 7089) and M10 nuts (ISO 4032).

Comply with a bolt torque of 21 Nm.

The diameters of the holes in the flange of the protected device for M10 screws are Ø12 mm (EN 20273).

The values of maximum vacuum are for VENT PRO T with a static opening pressure of 10 kPa.