



VENT PRO T - ROUNDED EXPLOSION VENTING DEVICE



It is a safety device designed to relieve and release an explosion that might occur inside the protected equipment, where there is an environment with a risk of explosion. Under normal operating conditions, the relief area on the protected equipment is covered by VENT PRO T. If the p_{stat} is exceeded during an explosion inside the equipment, VENT PRO T will open, thus releasing the pressure from the jeopardized area. The equipment will be exposed to a pressure lower than its pressure resistance.

This data sheet describes the technical parameters of VENT PRO T. These VENT PRO T have a convex three-layer construction and high vacuum resistance. They are manufactured in a rounded and rectangular design and they are in accordance with EN 14797 and European Directive 2014/34/EU.

VENT PRO T CLASSIFICATION

Equipment group	II
Explosive atmosphere	G, D
Equipment category, indoor/outdoor	1/2G, 1/2D
Operating temperature	-40 °C to 240 °C
Storage temperature	-10 °C to 40 °C
Standard static opening pressure*	10 kPa +/- 15 %

* Can also be supplied with a different static opening pressure

MATERIAL DESIGN

VENT PRO T	stainless steel
Sealing	PTFE

OPTIONAL ACCESSORIES

Opening indicator	cable (G1), magnetic (G2), additional (G3) or induction (G4)
Intrinsically safe relay	it is used to create the interface between the safe and dangerous zone
Flange gasket	EPDM, silicon
Thermal insulation	synthetic rubber-based foam
Fasteners	screws - (strength 8.8 or A2-70), nuts ISO 4032, washers ISO 7089 (all in galvanized finish or stainless-steel design)
Upper frame	made of stainless steel or constructional steel, galvanized

DIMENSIONAL DIAGRAM

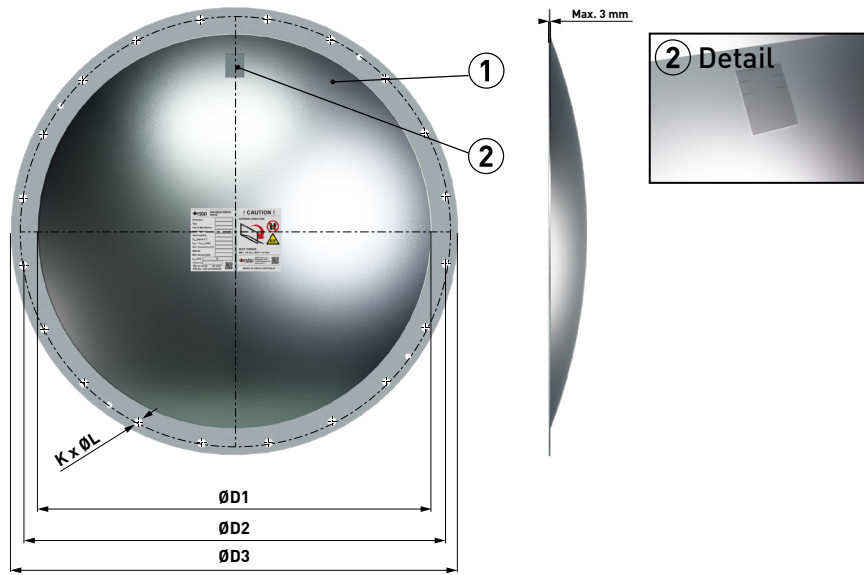

INSTALLATION VARIANTS

Installing with bolts

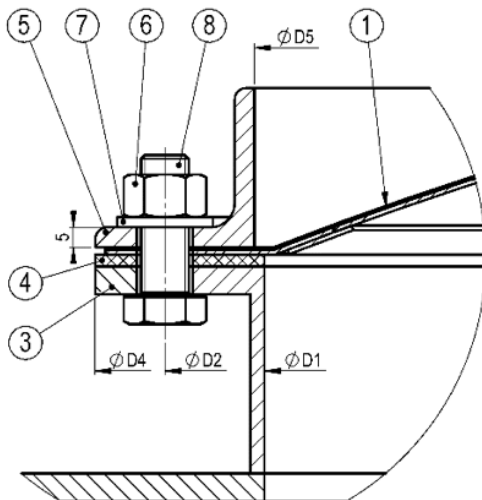

Installing with welded screws

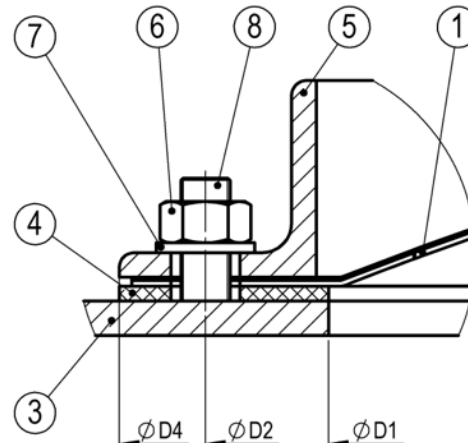

Position	Components	Quantity
①	VENT PRO T	1
②	opening indicator plate VENT PRO	1
③	protected equipment ¹⁾	1
④	flange gasket ⁵⁾	1
⑤	upper frame ^{2), 3)}	1
⑥	nut ³⁾	see ⁴⁾
⑦	washer ³⁾	see ⁴⁾
⑧	screw ³⁾	see ⁴⁾

¹⁾ For the installation of VENT PRO T, the flange of the protected equipment must meet the requirements of standard EN ISO 13920-BE and must be sufficiently rigid. In case of mounting on insufficiently rigid equipment, it is necessary to provide the flange with additional reinforcement.

The diameters of the holes in the flange of the protected device for M10 screws are Ø12 mm, for M8 screws are Ø10 mm (EN 20273).

²⁾ The frame is made out of 40x40x5 L-shaped steel. In the case of VENT PRO T DN 300, the frame is manufactured from the L 30x30x5 profile and the VENT PRO T DN 900, 1000 and 1100 are manufactured from the L 50x50x5 profile. In case there is a risk of rainwater remaining in the upper frame, it is necessary to create drainage channels 12 mm wide and 5 mm high in suitable places in it.

³⁾ Material - galvanized steel or stainless steel (screws strength 8.8 or A2-70).

⁴⁾ Number according to technical parameters table.

⁵⁾ A suitable sealant can be used instead of the flange gasket.

TECHNICAL PARAMETERS

Dimensions	Vent area [m ²]	Hole dimension in protected equipment ØD1 [mm]	Spaced circle ØD2 [mm]	VENT PRO external dimension ØD3 [mm]	External dimension of the frame, seal and flange of the protected equipment ØD4 [mm]	Internal dimension of the frame ØD5 [mm]	Screws /Holes in VENT PRO			Max. vacuum [bar]
							K [ks]	ØL [mm]	Screw size ISO 4017	
DN 250	0.05	265	320	345	350	270	12	11	M8	-1.00
DN 300 ¹⁾	0.06	315	350	375	380	320	12	11		
DN 350	0.07	340	387	420	425	345	12	11		
DN 400	0.10	390	443	475	480	400	16	13	M10	
DN 450	0.13	445	486	525	530	450	12	14		
DN 510	0.17	505	550	585	590	510	20	14		
DN 600	0.24	595	646	675	680	600	20	14		
DN 630	0.27	625	680	705	710	630	20	14		
DN 750	0.41	765	817	845	850	770	28	14		
DN 800	0.47	815	860	895	900	820	24	14		
DN 880	0.56	875	920	955	960	880	24	14		
DN 900 ²⁾	0.57	895	955	995	1000	900	32	14		
DN 1000 ²⁾	0.72	995	1060	1095	1100	1000	36	13	-0.85	
DN 1100 ²⁾	0.87	1095	1160	1195	1200	1100	40	14		

use of the standard L profile frame 40x40x5

¹⁾ use of the L profile frame 30x30x5

²⁾ use of the L profile frame 50x50x5

ØD1 Hole dimension in protected equipment.

ØD1, ØD4 and ØD5 see installation variants.

Use screws, flat washers (ISO 7089) and nuts (ISO 4032) to secure the rounded VENT PRO T.

Comply with a bolt torque of 15Nm (for M8) and 21Nm (for M10).

The diameters of the holes in the flange of the protected device for M10 screws are Ø12 mm, for M8 screws are Ø10 mm (EN 20273).

The values of maximum vacuum are for VENT PRO T with a static opening pressure of 10 kPa.