



FLAMMER

Intelligent
Safety
Solutions

Portable Spring Loaded Safety Relief Valves

Series 9



Introducing Flammer Technologies Pvt. LTD.

Flammer Technologies Pvt. LTD. provides critical service safety valves, rupture discs, explosion protection equipment, specialist tank valves and on-site service.

Support for our supplied products. Our reputation is based on engineering excellence applied to a comprehensive range of specialist products and effective customer support.

We have the capability to deliver complete valve solutions for major projects in the power generation, oil and gas exploration and general industrial sectors. We specialize in the maintenance, upgradation and management of industrial assets at customer sites.

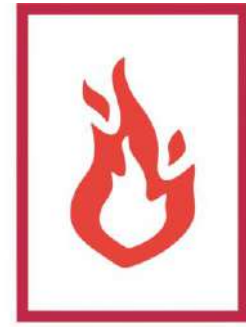

FLAMMER

Quality assurance

Flammer Technologies operates quality programs to cover the full scope of its activities. Comprehensive quality systems have been developed to serve the power, oil and gas and industrial markets which they serve.

The company complies with:

- ASME Section III 'N', 'NPT', 'NV' (Complies, Not Certified)
- ASME Section I 'V' (Complies, Not Certified)
- ASME Section VIII 'UV' (Complies, Not Certified)
- EN ISO 9001: 2008
- EN ISO 14001: 2004
- OHSAS 18001: 2007
- API Q1 TO API LICENCES API 6D (6D-0182) AND API 6A (6A-0445)
- API STD 520
- API STD 526
- API STD 527
- API STD 2000
- ISO 4126

The Quality systems have been approved for the supply of products to meet the requirements of the Pressure Equipment Directive (PED) and compliance modules A, D1, H, B&D have been applied in categories I through IV respectively.

The company is committed to compliance with legislation and has an established environment and health and safety policy.

An ongoing commitment to customer care is met through the process of continuous improvement and the further development of our systems and processes towards meeting ISO 9001.

Material testing service available

- Non-destructive examination by radiography, ultrasonic, magnetic particle and liquid penetrant.
- Chemical analysis by computer controlled direct reading emission spectrometer.
- Mechanical testing for tensile properties at ambient and elevated temperatures, bend and hardness testing. Charpy testing at ambient, elevated and sub-zero temperatures.

Valve testing facilities

All pressure containing items are hydrostatically tested, seat leakage tested and functionally tested. In addition, gas, packing emission, cryogenic and advanced functional testing can be arranged.

Further technical information can be obtained from our Web site: <http://www.flammertech.com>



Flammer Technologies Pvt. LTD. manufactures the FLAMMER range of 9 Series and 66 Series pressure safety valves and safety devices for oil and gas, petrochemical and chemical industries, pipelines, thermal and nuclear power plants, sugar refineries and pulp mills

The FLAMMER range of products is manufactured in two of our factories located in Vadodara, India accordance with ASME, API and ISO standards and therefore can meet most of worldwide customers' requirements. The company complies with:

EN ISO 9001:2008
EN ISO 14001:2004
OHSAS 18001:2007
PED 97/23/EC Module B+D Category IV (Complied)
ATEX 94/9/EC
ASME Section I 'V' - ASME Section VIII 'UV' API STD 520
- API STD 526 - API STD 527 API STD 2000
ISO 4126 SELO
ROSTECHNADZOR KGS

Specifically, Flammer Technologies Pvt. LTD. can design and manufacture special valves to meet special customer requirements.

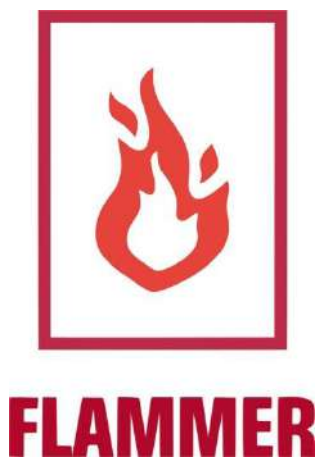

CONTENTS

Introduction	4
Dimensions	5
Materials	7
Accessories	10
Codifications	12

The 9 Series valves are designed and manufactured in compliance with International standards (ASME B&PVC Section VIII Division 1, EN ISO 4126 Part 1).

The 9 Series comply with most overpressure protection requirements in the following industries: oil & gas, petrochemical, chemical and many other general industries.

General

- Full lift
- Full Nozzle
- Adjustable blowdown
- Use on Gas, Liquids, Steam
- Size: ½" to 1" ½
- Set Pressure up to 430 barg (6250 psig)
- Temperature: up to 400°C (752°F)

Connections

• Screwed

Inlet: NPT male (female on request)
BSP male
Outlet: NPT female
BSP cylindrical female

• Flanged

Inlet: Loose captive flange
Outlet: Screwed or flange
Type: ASME B16.5, EN 1759-1, EN 1092-1,
Other standard on request

Concept

- Adjusting ring for perfect popping and blowdown adjustment
- Metal/metal seating

Construction

- Body: Carbon steel (SA 216 Gr WCC)
Stainless steel (SA 351 Gr CF3M)
Exotic material
- Trims: Stainless-steel
Exotic material

Options

- Packed lifting lever
- Test gag
- Bellows (*metal seat - D & F orifices*)
- Soft seat
- Balanced Piston (*soft seat*)



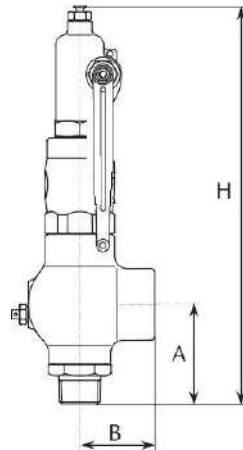

Screwed

Orifices & Dimensions

Actual Flow Coefficient

Gas: 0.975

Liquid: 0.632

Orifice	Type	Inlet Max Set Pressure		Outlet Max Back Pressure		Dimensions			Weight (Kg)
		barg	psig	barg	psig	A mm	B mm	H mm	
B actual area : 0.283 cm ² /0.044 in ²	1/2" x 1/2"	155.2	2250	51.7	750	43.5	40	242	1.8
	1/2" x 1"	155.2	2250	20.0	290	47.5	40	242	1.8
		431.0	6250	51.7	750	63.0	85	344	6.5
	3/4" x 1"	155.2	2250	20.0	290	50.5	40	245	1.8
		431.0	6250	51.7	750	63.0	85	344	6.5
D actual area : 0.801 cm ² /0.124 in ²	1" x 1"	155.2	2250	20.0	290	50.5	40	245	2
		431.0	6250	51.7	750	69.0	85	350	6.7
	3/4" x 1"	103.4	1500	51.7	290	64.0	50	255	2
E actual area : 1.431 cm ² /0.222 in ²	1" x 1"	103.4	1500	51.7	290	70.0	50	262	2.2
		258.6	3750	51.7	750	69.0	85	350	6.7
	3/4" x 1"	51.7	750	20.0	290	64.0	50	255	2
F actual area : 2.270 cm ² /0.352 in ²	1" x 1"	155.2	2250	51.7	750	63.0	85	344	6.5
		51.7	750	20.0	290	70.0	50	262	2.2
	155.2	2250	51.7	750	69.0	85	350	6.7	
G actual area : 3.664 cm ² /0.568 in ²	1" x 1 1/2"	51.7	750	20.0	290	91.0	60	325	4.3
	1 1/2" x 1 1/2"	51.7	750	20.0	290	91.0	60	325	4.3
G actual area : 3.664 cm ² /0.568 in ²	1" x 1 1/2"	20.0	290	20.0	290	91.0	60	325	4.5
	1 1/2" x 1 1/2"	20.0	290	20.0	290	91.0	60	325	4.5

Flanged

Orifices & Dimensions

Actual Flow Coefficient

Gas: 0.975

Liquid: 0.632

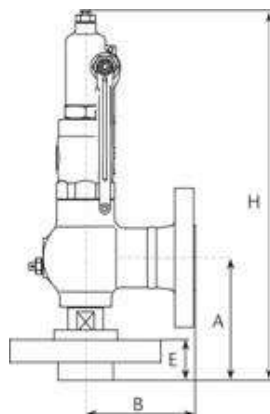

Flanged																						
Orifice	Type	Inlet		Class	Class	Outlet		Dimensions				Weight (Kg)										
		Max Set Pressure				Max Back Pressure		A	B	E	H											
		barg	psig	ASME (1)	ASME (1)	barg	psig	mm	mm	mm	mm											
B actual area 0.283 cm ² /0.044 in ²	1/2" x 1"	19.7	285	150	150	19.7	285	90	85	26.8	285	3.6										
		51.0	740	300						29.8		4										
		102.1	1480	600						29.8		4										
		153.1	2220	900						300		51.0	740	90	90	38.5	285	6				
		255.5	3705	1500										115	120	38.5	400	10.2				
		425.5	6170	2500										45.8	400	11.5						
	3/4" x 1"	19.7	285	150	150	19.7	285	90	85	28.3	285	4										
		51.0	740	300						31.3		4.5										
		102.1	1480	600						31.3		4.5										
		153.1	2220	900						300		51.0	740	105	90	41	300	6.6				
		255.5	3705	1500										115	120	41	400	11				
		425.5	6170	2500										47.4	400	12.1						
	1" x 1"	19.7	285	150	150	19.7	285	90	85	29.9	285	4.4										
		51.0	740	300						33.1		5										
		102.1	1480	600						33.1		5										
		153.1	2220	900						300		51.0	740	120	90	44	31.5	8				
		255.5	3705	1500										115	120	44	400	12.3				
		425.5	6170	2500										50.6	400	14						
D actual area 0.801cm ² /0.124in ²	1/2" x 1"	19.7	285	150	150	19.7	285	95	85	28.3	290	4										
		51.0	740	300						31.3		4.5										
		102.1	1480	600						31.3		4.5										
	3/4" x 1"	153.1	2220	900	300	51.0	740	115	120	41	400	10.9										
		255.5	3705	1500						41		10.9										
		19.7	285	150						150		19.7	285	95	85	29.9	290	4				
	51.0	740	300	33.1	4.6																	
	102.1	1480	600	33.1	4.6																	
	153.1	2220	900	300	51.0	740	115	120	50.6		400					10.9						
	255.5	3705	1500				50.6	400	12.3													
	19.7	285	150				150	19.7	285		95					85		28.3	290	4.2		
	51.0	740	300	31.3	4.8																	
102.1	1480	600	31.3	9																		
153.1	2220	900	300	51.0	740	115				120		41	400	11								
19.7	285	150				150				19.7		285	95	85	29.9		290	4.2				
51.0	740	300													31.1			5				
102.1	1480	600	31.1	9.5																		
153.1	2220	900	300	51.0	740		115	120	44		400				12.3							
19.7	285	150					150	19.7	285		115				110	15.8		350	7.8			
51.0	740	300														19.1			8.5			
19.7	285	150	150	19.7	285	115				110		33.1	350	8.5								
51.0	740	300										36.2		10								
19.7	285	150										150		19.7		285	115		110	15.8	350	7.8
19.7	285	150																		150		19.7

(1) Comply with EN 1759-1 - EN 1092-1 (Former DIN) on request.

(2) Integral flange for ASME B16.5 connections

9 SERIES – Standard configuration

Materials for standard applications, high temperature, low temperature and corrosive fluids

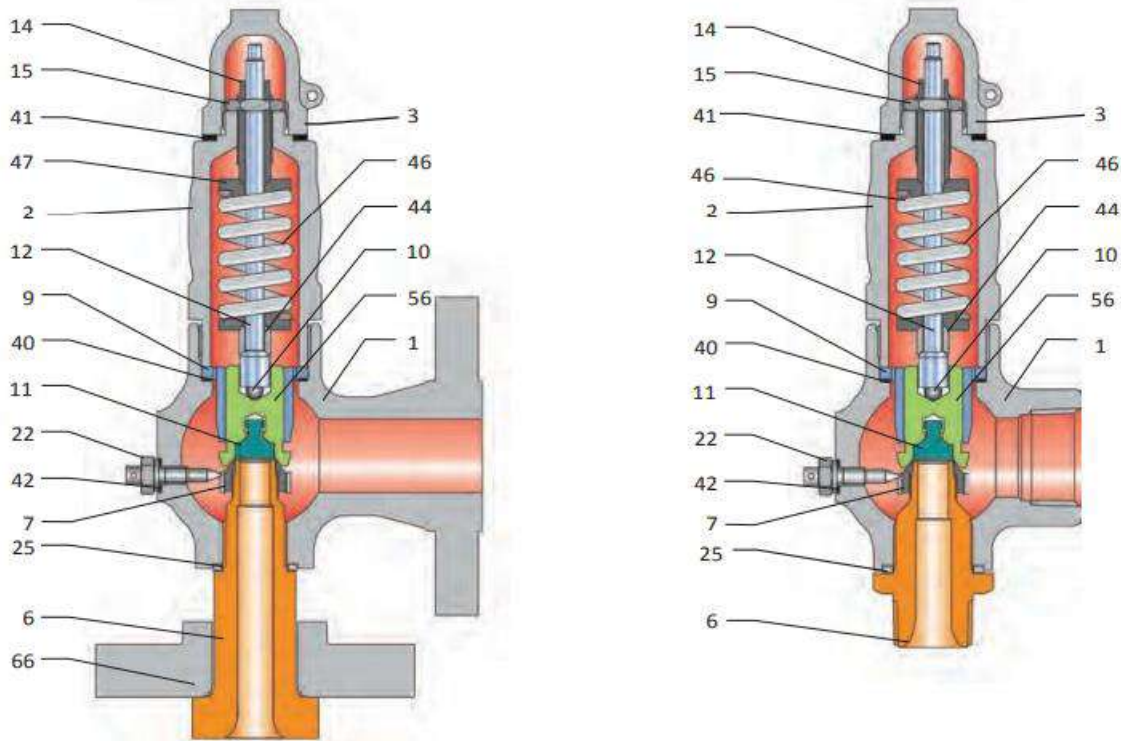

Tag	Designation	Standard Material	
		Carbon Steel Material Code A	Stainless Steel Material Code X
1	Body	SA 216 Gr WCC	SA 351 Gr CF3M
2	Bonnet	CS LF2 or SS 316L	SA 351 Gr CF3M or SS 316L
3	Cap	SA 216 Gr WCC or SS 316L	SA 351 Gr CF3M or SS 316L
6	Nozzle (Base)	SS 316L	SS 316L
7	Adjusting Ring	SA 351 Gr CF3M	SA 351 Gr CF3M
9	Guide	SS 17.4 PH	SS 17.4 PH
10	Ball	CS	SS
11	Disc	SS 316L	SS 316L
12	Spindle	13% Cr or SS 316L	SS 316L
14	Adjusting Screw	SS 316L	SS 316L
15	Lock Nut	SS 316L	SS 316L
22	Adjusting Ring Screw	SS 316L	SS 316L
25	Nozzle Gasket	SS 316L	SS 316L
40-41-42	Gasket		SS
44	Spacer	SS 316L	SS 316L
46	Spring		SS304 or Alloy X750
47	Spring Washers (Upper & Lower)	CS	SS 316L
56	Disc Holder	SS 316L	SS 316L
66	Lapped Flange	SA 105 LF2	SS 316L

- Notes:
1. Stellite seat for 900# and over for B and D orifices.
 2. Other materials (such as superalloy) on request.

9 SERIES – Special configuration

Materials for Cryogenic and Liquefied Natural Gas.

Liquefied Natural Gas and more generally cryogenic applications require special features for the internal materials.

End-users and contractors must be aware that any leakage on cryogenic applications could create an ice ball around the seat and affect the pressure safety valve reliability.

In order to prevent any leakage due to seat damage, the use of soft seat can be considered.

Tag	Designation	Material for Cryogenics and LNG below -46°C
1	Body	SA 351 Gr CF3M or SS 316L
2	Bonnet	SA 351 Gr CF3M or SS 316L
3	Cap	SA 351 Gr CF3M or SS 316L
6	Nozzle	SS 316L
7	Adjusting Ring	SA 351 Gr CF3M
9	Guide	SS 316L
10	Ball	SS
11	Disc	SS 316L
11a	Soft Seat	See Soft Disc Material Table
12	Spindle	SS 316L
14	Adjusting Screw	SS 316L
15	Adj. Screw Locknut	SS 316L
16	Washers	SS 316L
22	Adjusting Ring Screw	SS 316L
25	Nozzle Gasket	SS 316L
33	Thermal Spacer	SS 316L
34	Thermal Barrier	Bakelite®
35	Spacer Ring	Thermoglide
36	Ball	SS
40	Guide Gasket	SS
41	Cap Gasket	SS
42	Adj. R. Screw Gasket	SS
	Spacer	SS 316L
46	Spring	Alloy X750
56	Disc Holder	SS 316L
66	Lapped Flange	SS 316L
83	Retaining Screw	SS 316L

Soft Seat

Set Pressure	Soft Material
1 to 26 barg	PTFE
26 to 66 barg	PCTFE
66 to 200 barg	PEEK

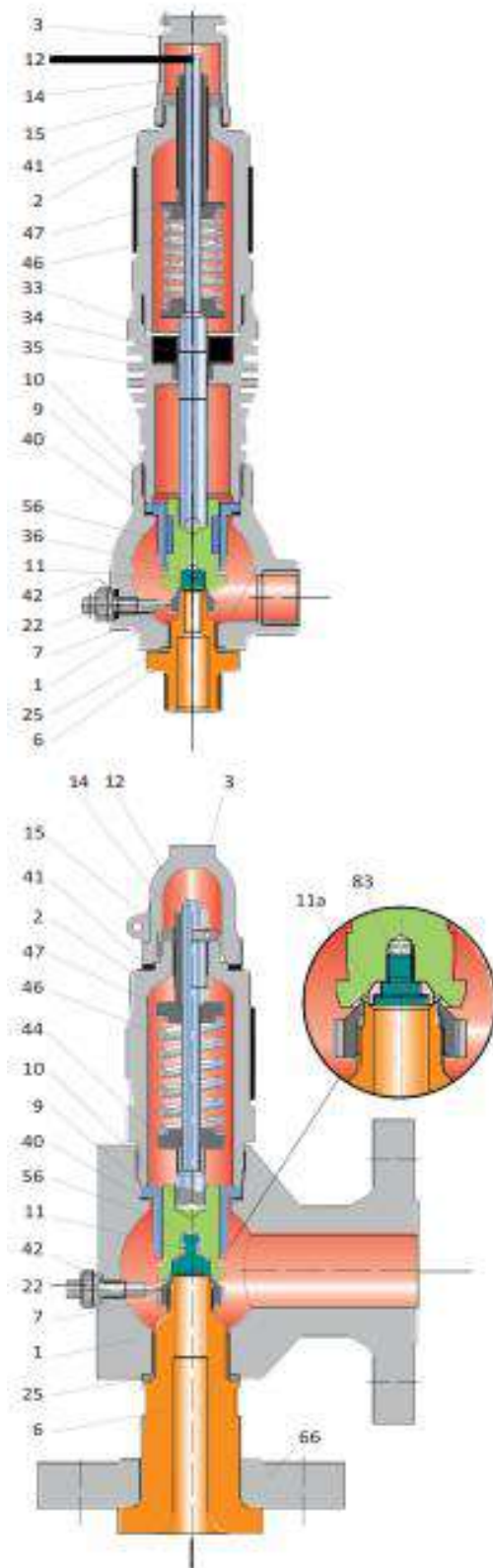

9 SERIES – Special Configuration

Materials for Corrosive and Sour Gas Services

Many process streams in the oil and gas industry contain enough H₂S to cause sulfide stress cracking (SSC) in susceptible materials. It exists in two different domains in which two different standards may be applicable:

- Oil and Gas production: NACE MR0175/ISO 15156
- Part 1 - 2001: General principles for selection of cracking-resistant materials
- Part 2 - 2003: Cracking-resistant carbon and low alloy steels, and the use of cast irons.
- Part 3 - 2003: Cracking-resistant CRAs (corrosion-resistant alloys) and other alloys.
- Oil and gas refining: NACE MR0103

The last revisions of NACE MR0175/ISO 15156 shows results of the inadequacy of some standard materials commonly used in the oil and gas industry. We then highlight this point and ask the end-user to clearly specify the condition of use (fluid details, pressure and temperature) in order to be able to select acceptable materials.

Flammer Technologies manufactures a large variety of valves used in sour service. Based on our experience and the last edition of the standards, the definition of the actual critical components in a pressure safety valve should be mutually agreed between the purchaser and Flammer Technologies.

Please note, materials are applicable for NACE MR0175 / ISO 15156 according to the different paragraphs of the standard. As a first approach, we can note the following:

Materials	Paragraph
SA 352 Gr LCC	MR0175/ISO 15156-2 A2-1-2
SA 216 Gr WCC	MR0175/ISO 15156-2 A2-1-2
SA 217 Gr WC6	MR0175/ISO 15156-2 A2-1-2
SA 479 Gr 316L	MR0175/ISO 15156-3 A2-2
UNS S31803	Table 2 MR0175/ISO 15156-3 A7-2
UNS N06625	Table 24 MR0175/ISO 15156-3 A4-2
UNS N07750	Table 13 MR0175/ISO 15156-3 A2-9 Table 36

As an example of selection, Flammer Technologies can advise the following valve configuration. The conditions here are not so restrictive: temperature limited to 149°C (300°F).

SGA application : applicable on primary side only

Part N°	Part Name	Material	Applicable Paragraph
1	Body	SA 216 Gr WCC	MR0175/ISO 15156-2 ¶ A2-1-2
6 + 11	Nozzle & Disc	SS 316L	MR0175/ISO 15156-3 ¶ A7-2 Table A24
	Other parts	Standard	

Note: Above 233°C (500°F), parts 6-11 will be proposed in UNS N06625 (Alloy 625).

SGB application: applicable on primary and secondary sides

Part N°	Part Name	Material	Applicable Paragraph
1	Body	SA 216 Gr WCC	MR0175/ISO 15156-2 ¶ A2-1-2
2	Bonnet	SA 216 Gr WCC	MR0175/ISO 15156-2 ¶ A2-1-2
4	Cap	SA 216 Gr WCC	MR0175/ISO 15156-2 ¶ A2-1-2
6 + 11	Nozzle & Disc	SS 316L	MR0175/ISO 15156-3 ¶ A7-2 Table A24
9	Guide	SS 316L	
19	Balanced Bellows	UNS N06625 (Alloy 625)	MR0175/ISO 15156-3 ¶ A4-2 Table A13
46	Spring	Alloy X750	
	Other parts	Standard	

Note: Above 233°C (500°F), parts 6-11-19 will be proposed in UNS N06625 (Alloy 625).

Accessories

1) Packed lifting lever

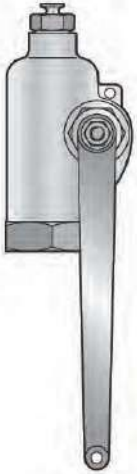

2) Balanced Bellows
(D & F Orifices)

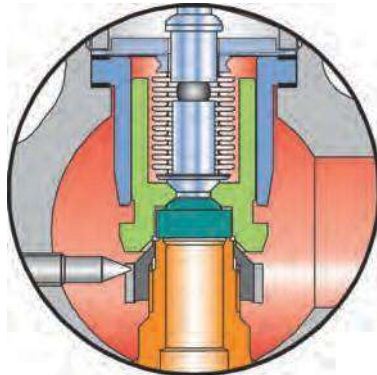

3) Test gag

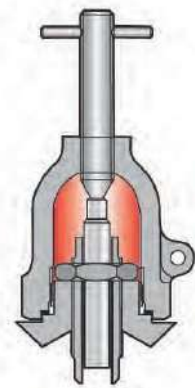

4) Butt-Welding fittings inlet & outlet
(3 pieces union couplings)

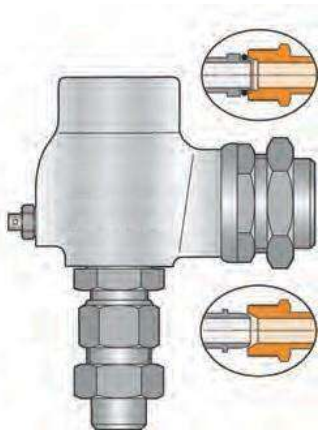

Type V
on request

Type S
Standard

5) Inlet "Clamp" connection

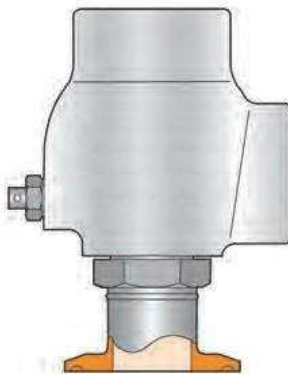

6a) Conventional Soft seat

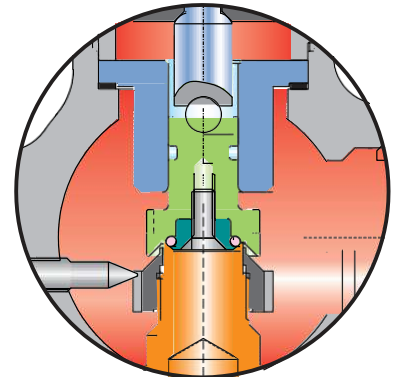

6b) Balanced Soft seat

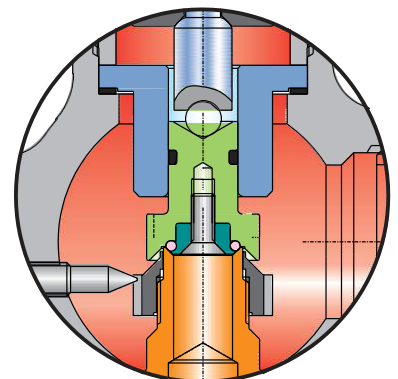

Soft Seat

Set Pressure	Soft Material
1 to 26 barg	PTFE
26 to 66 barg	PCTFE
66 to 200 barg	PEEK

Note: these values are applicable upto 25°C - for higher temperature, please consult the factory.

Special Application - Customer Specific Safety Valves

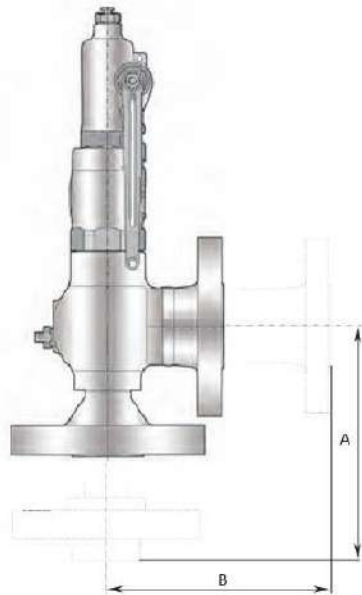

Custom A & B dimensions on request

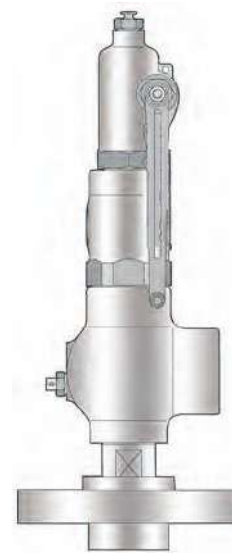

Mixed connections on request

Notes:

1 - Flammer Technologies can produce any forged body arrangement in order to meet high pressure or temperature and special dimensions.

2- On application, Flammer Technologies can supply the 9 Series (special) up to 990 barg (14,358 psig) with an orifice C of 0.385 cm² (0.0596 in²).

Codification

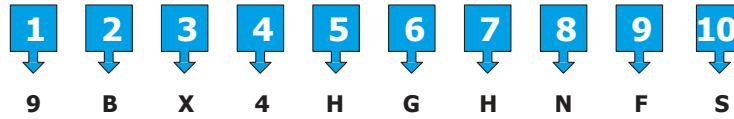

1 → **Type : 9**

2 → **Orifice :**
– (B-D-E-F-G)

3 → **Material of Construction :**

- 10 : A 351 Gr CF3M (Cryogenic)
- A : A 216 Gr WCB (Std Application)
- X : A 351 Gr CF8M (Std Application)
- A201 to A206 : Alloy 20
- AL1 & AL6 : Alloy 625
- AY1 & AY6 : Alloy 825
- AV1 & AV6 : Alloy 254 SMO
- CN1 & CN7 : A 351 Gr CN3MN
- D1 & D6 : Duplex
- H1 & H6 : Alloy C
- M1 & M6 : Alloy 400
- SD1 & SD6 : Superduplex
- MRA & MRB : NACE MR0103
- SGA & SGB : NACE MR0175 / ISO 15156

4 → **Inlet Pressure Class (ASME):**

– 1: 19.6 Bar g	4: 153 Bar g
– 2: 51 Bar g	5: 255 Bar g
– 3: 102 Bar g	6: 420 Bar g

5 → **Spring Material :**

– C: Carbon Steel	– I: Inconel
– P: SS304	– Q: SS316
– T: Tungsten Alloy	

6 → **Inlet Size :**

- F: ½"
- G: ¾"
- H: 1"
- K: 1½"

7 → **Outlet Size :-**

- F: ½"
- G: ¾"
- H: 1"
- K: 1½"

8 → **Connections :**

- A: Flanged as per ASME B16.5 (Equivalent to EN 1759-1)
- P: EN 1092-1
- K: Inlet Male con. BSP / Outlet Female cyl. BSP
- N: Inlet Male NPT / Outlet Female NPT
- N2: Inlet Female NPT / Outlet Female NPT
- Uy®: 3 piece union
- Z: Other

9, 10 → **Options :**

- A: Without accessories
- F: Packed lifting lever
- L: Lapped flange at the inlet
- P: Bellows
- V: Test gag
- S: Stellite disc and Nozzle
- SP: Special Requirements

The information is given for guidance only and can be revised without prior notice.



FLAMMER

M/S Flammer Technologies Private LTD, India

Works (Unit 1): Plot No. 108, GIDC Por-Ramangamdi, Vadodara-391243, Gujarat, India
Works (Unit 2): Plot No. 904/9, GIDC Makarpura, Vadodara-390010, Gujarat, India

Tel. Ph.: +91 96645 80047 (M) +91 95863 63631

Email: flammertech@gmail.com

GSTN: 24AAFCF7514C1Z1 CIN: U26517GJ2023PTC147265

© 2019 Flammer Technologies Pvt. LTD., All rights reserved.